

Assembly of Sides

Look at the sheet depicting the layout of the shelter and ensure that you are familiar with the position of the various bars.

Sketch 1

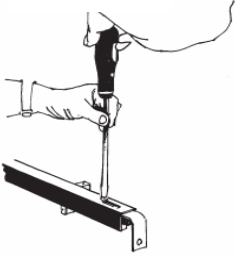

Select the uprights and attach the foot brackets. Sketch 1 using M6x12 screws

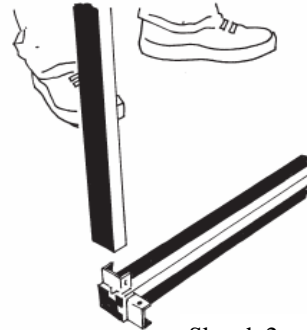

Select one of the corner uprights and two horizontal bars. With the securing lugs vertical, slide each of the bars over the lugs and secure with self tapping screws. See sketch 2

Sketch 2

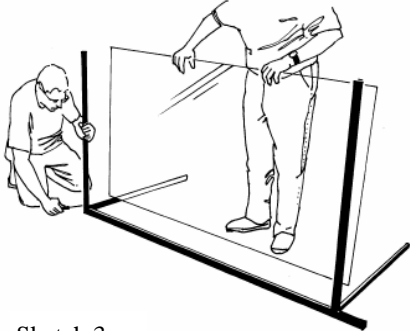

Sketch 3

Select and insert one of the plastic panels and complete panel by the addition of the next upright. See sketch 3 & 4 Note :- prior to securing with the self tapping screws ensure that there is no gap between the horizontal and vertical bars. If necessary the corners of the plastic may require relieving to ensure clearance.

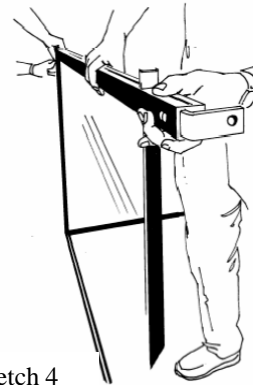

Sketch 4

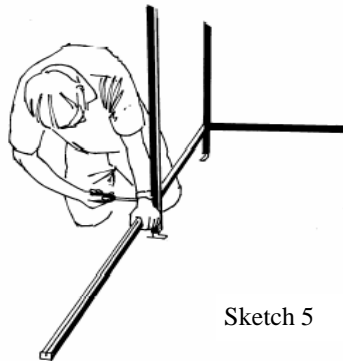

Sketch 5

Lift the assembled panels to the correct position and assemble the next section, thus completing the corner section. Sketch 5

Note at this time the unit is unstable and should not be left unattended.

Sketch 6



Continue to assemble the unit to the desired configuration.

Once all of the panels have been assembled, you should ensure that the shelter is level. If necessary the foot brackets can be adjusted. This is also an opportune time to ensure that all of the panels are square. This can be achieved by measuring the diagonals, that should be equal.



Sketch 7

Assembly Roof

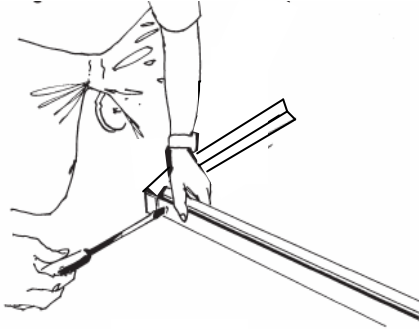

Sketch 9

Next, construct the roof frame. To undertake this slide the end units onto the side bars until the end angles are in line with the side channels. Note :- if the roof is in two sections then it will comprise of one end section and one or more joining sections. Prior to fixing the roof material ensure that the corners are square. Sketches 8 & 9

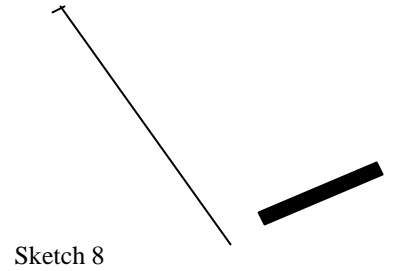

Sketch 8

Next the roof panels can be positioned with one roof section overlapping the other at the junction. Sketch 10 and secured with the trim strip and "T" section provided. Sketch 11 & 12. Use the silicon provided to ensure that the assembly is water tight.



Section through Junction. Sketch 10

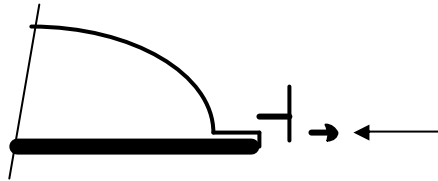

Sketch 11



Sketch 12

2 metre roof only

To provide stability at the centre of the roof a spacer is provided. Once the sides are fixed the spacer should be drilled (from the inside of the roof) with a 4mm drill and secured with a 5mm x 10 self tapping screw.

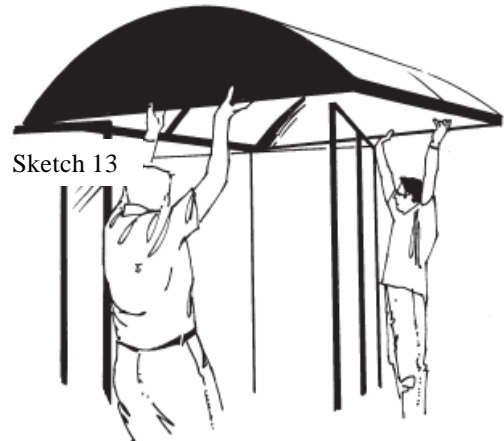

Sketch 13

Lift the roof section onto the frame ensuring that the securing lugs are correctly located. Note a stable platform must be used when raising the roof. All operatives must be advised of the correct lifting technique. If in doubt recruit additional personnel to undertake this task. Sketch 13

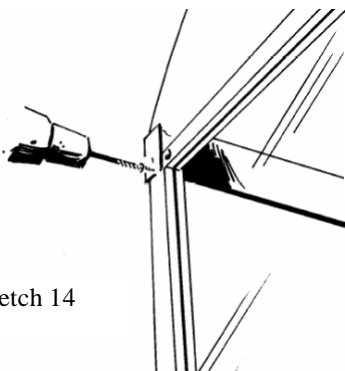

Sketch 14

Using drillscrews secure the roof via the rectangular securing plates. Sketch 14. These are located at the sides and ends of the unit. Note the securing plates at the corners are supplied loose and should be positioned as show in sketch 15 prior to fixing with drill screws in 4 places

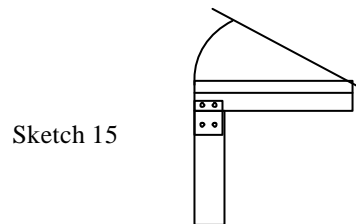

Sketch 15

Final Assembly and Fixing

Finally, insert the gasket into the outside edge of the panel channels. This is secured in place by tapping down with a small hammer using a small rectangle of wood as a punch. Prior to fitting the gasket you should ensure that the plastic panel is fitted centrally in the rebate.. Sketch 15 .

Note:- if the shelter is a Pavilion then the lower panels are secured with thicker gaskets.

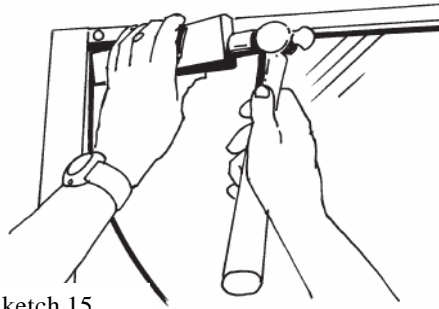

Sketch 15

When fitting the gasket to the lower rail it is easier to fit if the bar is supported from underneath. It is also prudent to check the roof joints if necessary apply a further bead of silicon sealant between the joining edges of the roof panels.

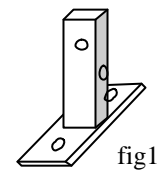

fig1

The schematic diagram will shown the position of the base fixings. If any of these are the Tube Foot Assembly see fig 1, they should be correctly positioned prior to drilling through the upright and securing with two M6x55 bolts..



On completion the shelter must be secured to the base with 8 mm bolts. Usually these are 100 mm long however the length and type of fixing will depend on the base material, but they must be suitable for retaining the shelter.